

Chesterton Connect™ Nano (2 Pack)

Increase Reliability with Multi-Function Monitoring

The Chesterton Connect Nano provides real-time monitoring of various parameters crucial to maintaining optimal operating conditions. Utilizing the Chesterton Connect™ Gateway, the Nano displays the measured parameters in the Chesterton Connect™ Cloud, facilitating historical data trends and 24/7 notifications when user-defined thresholds are exceeded. Combined with the Chesterton Connect Cloud, the Nano helps provide insights to improve maintenance, drive corrective actions, and optimize equipment performance.

Applications

- Pump skid, floor, or equipment vibration monitoring.
- Monitoring surface and room temperature.
- Liquid detection due to leaks or flooding.
- Tracking on/off status of equipment.
- Measuring equipment runtime and cycle count.

SPECIFICATIONS

Operating Parameters

Vibration	Total RMS velocity of XYZ and peak acceleration (16 g max)
Temperature Limit	-20°C – 85°C (-4°F – 185°F)
Power	2-year non-replaceable battery (CR2477X)
Mounting	Magnetic or bracket mount
Moisture Detection	Liquid contact
Certifications	IP66, FCC, IC, CE, RoHS
Temperature Output Accuracy	±3°C (±5°F)
Wireless	Bluetooth® 4.2

Software

- Secured encrypted data transfer
- Easy registration through the Chesterton Connect™ App
- Measurement transfer rate: 5-minute intervals using Chesterton Connect™ Gateway
- Seamless integration with the Chesterton Connect™ Cloud

For additional information, please contact Chesterton engineering at connect.support@chesterton.com.



Chesterton Connect™

Advantages

- **Early detection of issues:** Helps identify potential issues before they lead to equipment failure.
- **Improves maintenance operations:** Provides critical insights to optimize maintenance schedules and actions.
- **Easy installation and configuration:** Simplifies setup with multiple mounting options.
- **Secure data access:** Ensures that your data is encrypted and accessible through secure platforms.
- **Versatile Monitoring:** Offers multiple monitoring functions in one compact device. Requires Chesterton Connect Gateway.



Contents:

- 2 Chesterton Connect Nano smart sensors
- 2 Mounting brackets with bolts

Recommended Installation Locations

Surface vibration, temperature, on/off status

- 1 Motor housing
- 2 Inboard bearing
- 3 Outboard bearing

Moisture detection, ambient temperature and vibration

- 4 Pump base

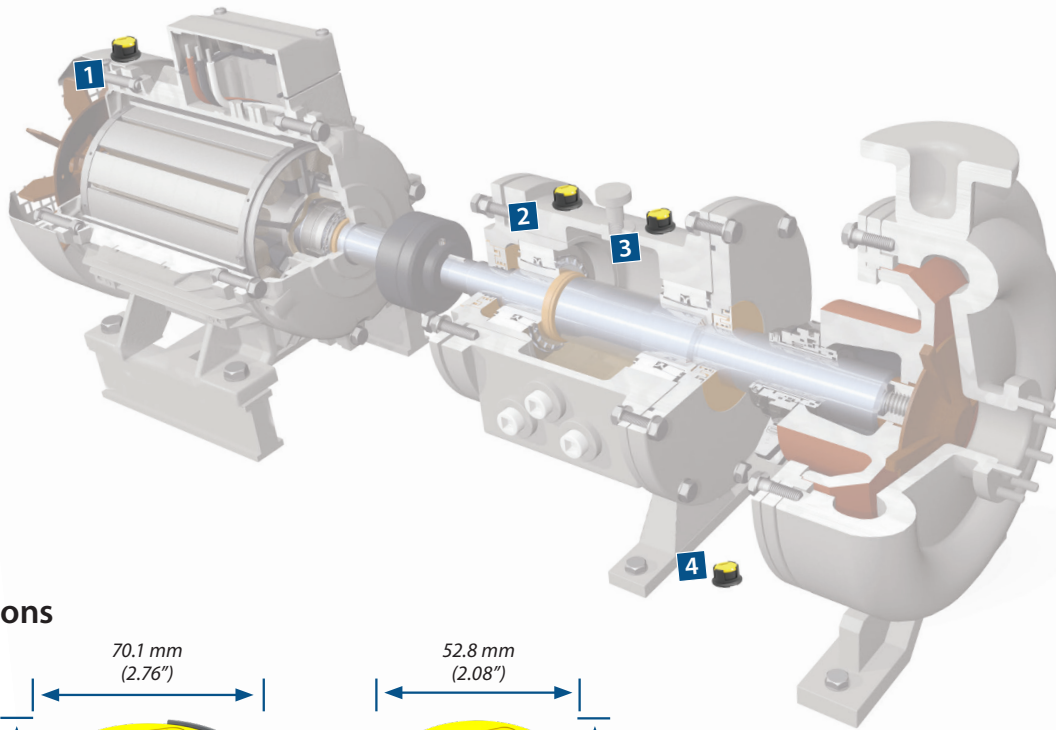

Dimensions

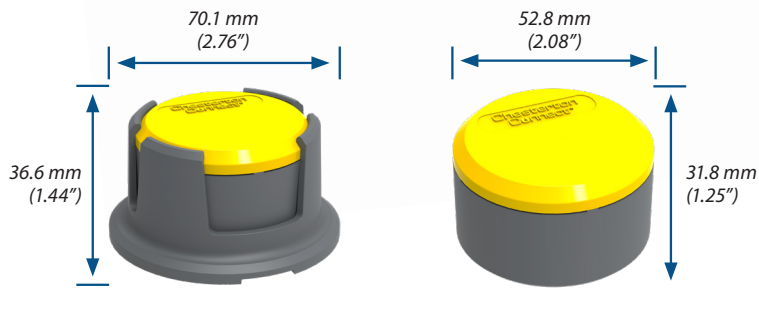

Product Order Number: 435719

Chesterton Connect™ is a trademark of A.W. Chesterton Company. The Bluetooth® word mark and logos are registered trademarks owned by Bluetooth SIG, Inc. and any use of such marks by A.W. Chesterton is under license. Apple, the Apple logo is a trademark of Apple Inc., registered in the U.S. and other countries. App Store is a service mark of Apple Inc. Google Play, the "Android" name, the Android logo, the "Google play" brand, and other Google trademarks, are property of Google LLC.

Technical data reflects results of laboratory tests and is intended to indicate general characteristics only. A.W. Chesterton Company disclaims all warranties express or implied, including warranties of merchantability and fitness for a particular purpose. Liability, if any, is limited to product replacement only. Any images contained herein are for general illustrative or aesthetic purposes only and are not intended to convey any instructional, safety, handling or usage information or advice respecting any product or equipment. Please refer to relevant Safety Data Sheets, Product Data Sheets, and/or Product Labels for safe use, storage, handling, and disposal of products, or consult with your local Chesterton sales representative.

© 2024 A.W. Chesterton Company
® Registered trademark owned by A.W. Chesterton Company in USA and other countries, unless otherwise noted.

Distributed by: