

TYPE

.....
VSA

SEWAGE PUMP



Capacities to 1600 gpm, Heads to 120',
Horsepower range 3/4 thru 40, 3" thru
6" discharge, 1750 and 1150 operation.

HIGHLIGHTS

-  Wet-Pit Installations
-  Pumps Suspend From Pit or Basin Cover
-  Non-Clog Impellers
-  1750 rpm and 1150 rpm Operation
-  Steel or Fiberglass Basins
-  Steel Covers and Grouting Frames for Concrete Pits
-  Control Systems Available

INSTALLATION DIAGRAM

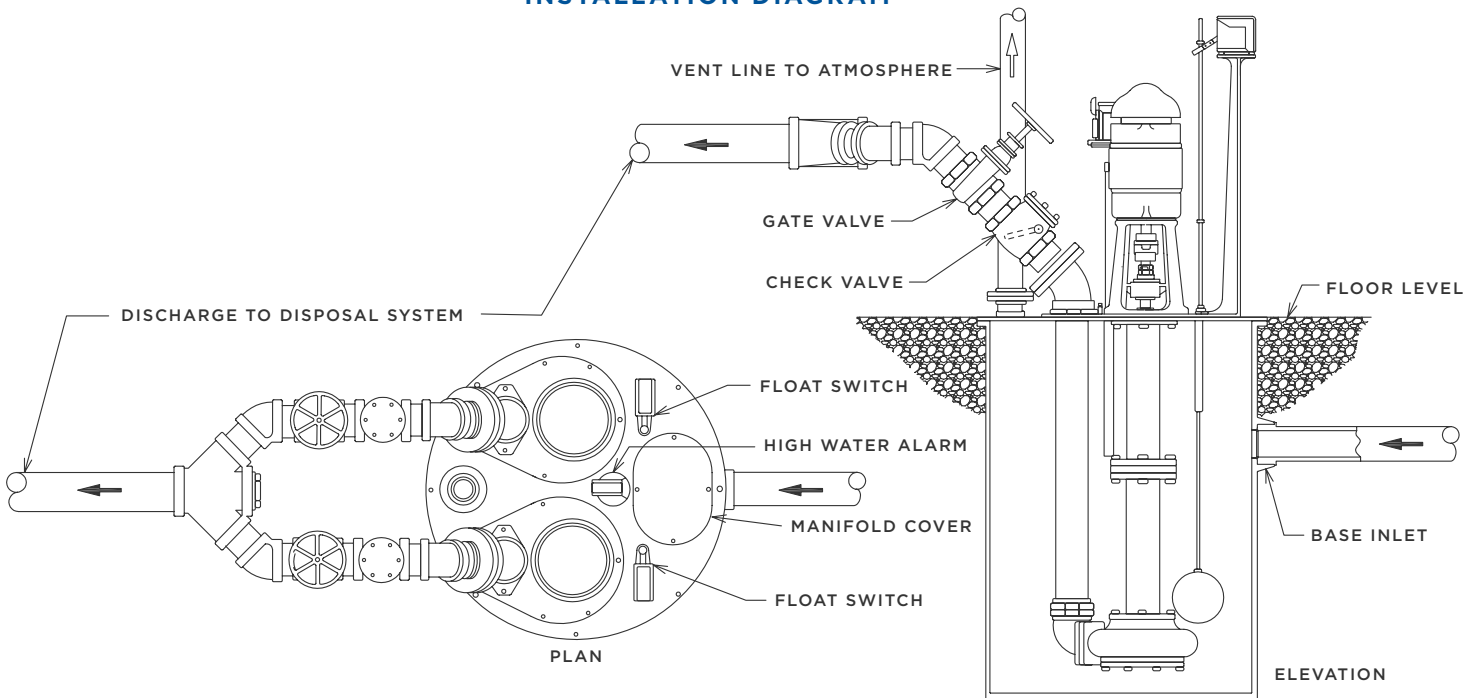

PUMP AND BASIN SIZING

PUMP CAPACITY

Type VSA sewage pumps are used to handle sewage and other liquids containing solids where gravity drainage is not practical.

Single pump units may be used but duplex units are recommended so that, in the event of failure of one pump, the second pump is available to handle the in-flow. Duplex units are required by the National Plumbing Code when more than six water closets are handled.

Each pump of a duplex set is sized to handle the full pump capacity. Pump capacity can be determined by the number of water closets to be handled. The capacities shown below apply to single pumps and to each pump of a duplex set.

Pump & Basin Sizing	
No. of Water Closets Handled	Pump Capacity (GPM)
1	50
2 OR 3	75
4 OR 5	100
6 OR 7	125
8 TO 10	150
11 TO 15	200
16 TO 20	250
21 TO 25	300
26 TO 30	350

Fixtures other than water closets need not be considered when using the above table. However, if outside drainage (see below) is greater than half the pump capacity shown above, add the excess amount of outside drainage to the pump capacity.

OUTSIDE DRAINAGE

Paved Area 10 g.p.m per 1,000 sq. ft. of area.

Tile Drainage Bed (Sandy Soil) 15 g.p.m per 1000 sq. ft. of bed.

Tile Drainage Bed (Clay Soil) 8 g.p.m per 1000 sq. ft. of bed.

UNUSUAL EXTRA IN-FLOW FACTORS

If drainage is to be handled by the sewage pumps from unusual sources such as boiler blow-down, air conditioning condensate, pools, display fountains, wash racks, etc., add this additional in-flow to the pump capacity.

PUMP DISCHARGE HEAD

The pump discharge head includes the following three elements:

Static Head The difference in elevation between the lowest water level in the basin (generally 1 ft. above the bottom of the basin) and the maximum height of the discharge line.

Friction Loss of head in the discharge line from friction through pipe, valves and other fittings.

Back Pressure In cases where the run-off sewer is charged, add for the sewer back pressure (generally from 2 ft. to 8 ft.)

Example Sewage basin is 5 ft. deep and set in ground with top flush with finished floor of basement. Basement floor is 10 ft. below highest point of pump discharge line. Pump capacity is 100 gpm. Size of discharge line is 4".

Static Head: 14 ft.
 Friction loss thru discharge pipe: 2 ft.
 Friction loss thru valves & fittings: 3 ft.
 Back pressure in charged sewer: 4 ft.
 Total pump discharge head: 23 ft.

PIT OR BASIN SIZE

For most installations, pit or basin diameters (or squares) can be the minimums shown in the table. In some cases, the minimum basin diameters shown can be reduced if space conditions require (consult the factory).

Pit or basin depth should be sufficient to allow 3 ft. below the inlet connection. The pump turn-on level is just below the inlet connection and the pump turn-off level is 1 ft. above the bottom of the basin. Therefore, each pump cycle will pump 2 ft. of water.

If job conditions require basins to be shallower than recommended, increase the basin diameter.

Capacities (in gallons) of round pits and basins per foot of depth are shown in the dimension table. To determine the capacity (in gallons) of a square or rectangular pit, multiply the cubic feet by 7.5.

FEATURES

MOTOR: Nationally known manufacturer. Single phase motors in fractional horsepower frame sizes have built-in overload protection. Other motors should be protected by magnetic starters.

FLEXIBLE COUPLING: Machined and balanced.

THRUST BEARING: Ball bearing mounted above suspension plate in dust-proof and moisture-proof housing.

ADJUSTING NUTS: Two bronze lock nuts for accurate vertical adjustment of impeller clearance.

SUSPENSION PLATE: Cast iron plate has integral strengthening ribs.

DISCHARGE PIPE: Steel, locked to suspension plate, held in bottom elbow by mating flange, forming bottom expansion joint.

TOP DISCHARGE ELBOW: Cast iron 45 degree F elbow with integral 125# ASA standard discharge flange and top expansion joint ring.

IMPELLER: One-piece, bronze or cast iron, non-clog, balanced, keyed and locked to shaft.

SHAFT: Carbon steel, turned and ground, sized for maximum load.

SUSPENSION LEG: Cast iron sections with integrally cast end flanges.

GUIDE BEARINGS: Renewable bronze sleeve type intermediate bearings for each four feet of unsupported shaft length plus bottom guide bearing in the pump casing.

CASING: Cast iron with smooth water passages.

LUBRICATION SYSTEM: Intermediate and bottom guide bearings are lubricated through flexible grease lines. Alemite fitting furnished above the suspension plate for each grease line.

BASINS AND PITS: Sewage basins of fiberglass or steel construction are available. Also, steel covers and grouting frames for concrete pits.

BOARD OF STANDARDS AND APPEALS LISTING: Federal VSA sewage pumps are listed and approved by the New York City Board of Standards and Appeals, Calendar No. 741-50-SA.

MODIFICATIONS AVAILABLE

DISCHARGE CONNECTION: Under-cover tee connections; special top discharge connections.

MATERIALS OF CONSTRUCTION: Bronze impeller; stainless steel shaft; all-bronze or all-iron pump; galvanized steel discharge pipe.

LUBRICATION SYSTEM: Solenoid operated water flush for guide bearings.

NON-STANDARD MOTORS: Totally enclosed or explosion-proof housings; special electrical ratings; other modifications.

SUGGESTED SPECIFICATIONS FOR ARCHITECTS AND ENGINEERS

Furnish and install as shown on plans a duplex VSA-_____ suspended wet-pit sewage pump unit as manufactured by Federal Pump Corp. Each pump shall be rated _____G.P.M. at _____ feet Total Dynamic Head, shall have a _____inch discharge and be built for a pit or basin _____ deep.

Impellers shall be cast iron non-clog balanced design; shafts carbon steel sized for maximum load; thrust bearings ball type mounted in moisture-proof housings mounted above the suspension plate; casings smooth-passage cast iron with renewable bronze sleeve bearing; renewable bronze sleeve intermediate bearings provided for each four feet of unsupported shaft length. Flexible grease line shall be provided for each shaft bearing; suspension plate cast iron with strengthening ribs; suspension leg sections cast iron with integral cast flanges on each end; discharge pipe steel with expansion joints at both ends; top discharge connection shall be 45 degree elbow with integral ASA standard flange.

Motors shall be _____hp, _____ phase, _____ cycles, _____volts, _____rpm, open, drip-proof ball bearing type.

Furnish a pedestal mounted alternating float switch to alternate the operation of the pumps and provide simultaneous operation when required. Furnish a pedestal mounted auxiliary float switch to turn on both pumps if the alternating float switch is inoperative. The alternating and auxiliary float switches shall have copper floats, brass rods, adjustable stops, galvanized rod guides and shall be equal to Federal Type FS-4.

Furnish a compression tube type high water alarm actuating switch with adjustable sensing tube and integral alarm horn, equal to Federal type FS-5.

Furnish for each motor a magnetic line voltage starter in wall mounting general purpose enclosure providing overload and low voltage protection and with a Hand-Off-Automatic selector switch in the cover.

Furnish a fiberglass or steel sewage basin _____ diameter x _____ deep with inlet as determined by job conditions. Basin shall have a steel cover with required openings for pumps, controls, manhole and vent connection and shall be treated with a corrosion resistant coating.

ALTERNATE FOR CONCRETE PIT:

Furnish a welded angle iron pit frame and heavy steel cover equal to Federal Type PF-1 for a concrete pit. _____x _____x _____ deep. Cover and frame are to be of gastight construction and treated with a corrosion resistant coating. Cover shall have required openings for pumps, controls, manhole and vent connection.

PIT & BASIN COVERS

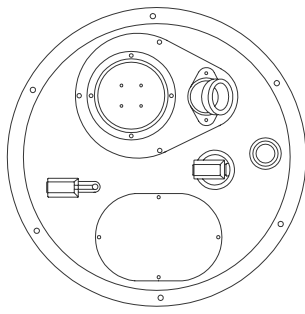

Simplex Unit
Round Pit or Basin

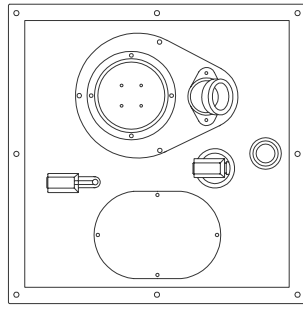

Simplex Unit
Square Pit

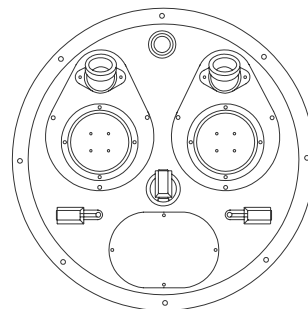

Duplex Unit
Round Pit or Basin

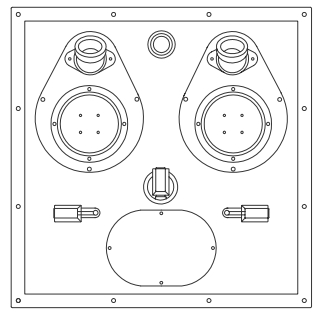

Duplex Unit
Square Pit

TYPES OF GROUTING FRAMES FOR CONCRETE PITS

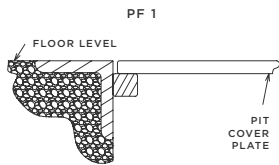

PF 1

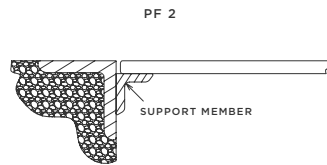

PF 2

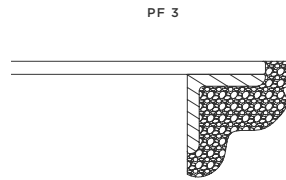

PF 3

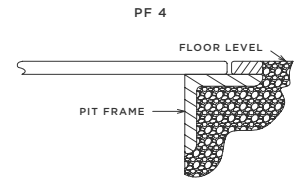

PF 4

CONTROL EQUIPMENT

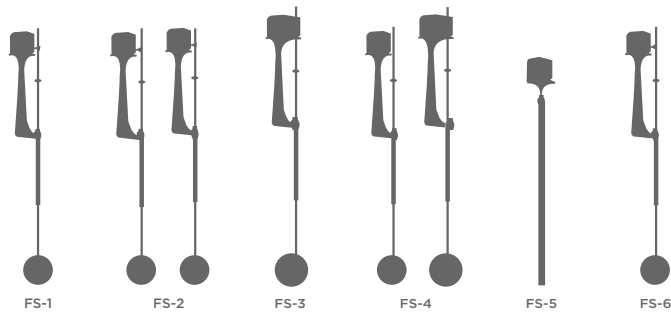

FS-1

FS-2

FS-3

FS-4

FS-5

FS-6



PUMP CONTROLS

The following control arrangements are available:

FS-1 (for single unit) - one float switch for start-stop control.

FS-2 (for duplex unit) - two float switches for start-stop control. The switches can be manually set to change the lead pump. Both pumps will operate if the in-flow rate requires.

FS-3 (for duplex unit) - one alternating float switch which operates the two pumps on an alternating basis and turns on both pumps simultaneously if the in-flow rate requires.

FS-4 (for duplex unit) - one alternating float switch (as described immediately above) plus two-pole emergency auxiliary float switch which will turn on both pumps at a predetermined high water level if the alternating float switch fails to operate for some reason.

FS-5 (for single or duplex unit) - a compression tube type high water alarm actuating switch with integral alarm horn. Can also provide signal for remote alarm indication. Alarm panel with bell, indicating light and silencing button is also available.

FS-6 (for single or duplex unit) - one float switch to act as a high water alarm actuator instead of the compression tube type described immediately above.

MOTOR CONTROLS

The following control arrangements are available:

For single or duplex units: (1) magnetic starter for each motor to be mounted on an adjacent wall or on the float switch pedestal(s).

For duplex units: A Type D Duplex Control Panel in a single enclosure for mounting on an adjacent wall. These panels are available as follows:

D1000: (2) magnetic starters in one enclosure.

D1100: (2) magnetic starters and (2) unfused disconnect switches in one enclosure.

D1200: (2) magnetic starters and (2) fusible disconnect switches in one enclosure.

D1300: (2) magnetic starters and (2) circuit breakers in one enclosure.

Modifications are available for magnetic starters and Type D Duplex Panels as follows: special enclosures, 'Hand-off-Automatic' selector switches, pilot lights, control circuit transformers, manual transfer switch and automatic pump alternator.

Selection Table 1750 RPM					
Unit No.	GPM	Disch. Head (ft.)	Motor HP	Disch. Size (ins.)	
VSA-4F-.75-4	50	21	0.75	4	
VSA-4F-1-4		26	1		
VSA-4F-1.5-4		33	1.5		
VSA-4F-2-A4		38	2		
VSA-4F-3-4		44	3		
VSA-4A-5-4		58	5		
VSA-4F-.75-4	75	18	0.75	4	
VSA-4F-1-4		25	1		
VSA-4F-1.5-4		32	1.5		
VSA-4F-2-4		37	2		
VSA-4F-3-4		43	3		
VSA-4A-5-4		56	5		
VSA-4F-.75-4	100	15	0.75	4	
VSA-4F-1-4		23	1		
VSA-4F-1.5-4		30	1.5		
VSA-4F-2-4		35	2		
VSA-4F-3-4		42	3		
VSA-4A-5-4		55	5		
VSA-4F-.75-4	125	12	0.75	4	
VSA-4F-1-4		20	1		
VSA-4F-1.5-4		26	1.5		
VSA-4F-2-4		33	2		
VSA-4F-3-4		38	3		
VSA-4A-5-4		53	5		
VSA-4F-1-4	150	16	1	4	
VSA-4F-1.5-4		23	1.5		
VSA-4F-2-4		31	2		
VSA-4F-3-4		36	3		
VSA-4A-5-4			52		5
VSA-4C-7.5-4		62	7.5		
VSA-4F-1-4	200	7	1	4	
VSA-4F-1.5-4		15	1.5		
VSA-4F-2-4		25	2		
VSA-4F-3-4		29	3		
VSA-4A-5-4			47		5
VSA-4C-7.5-4		60	7.5		
VSA-4A-1.5-4	250	8	1.5	4	
VSA-4A-2-4		16	2		
VSA-4A-3-4		25	3		
VSA-4A-5-4		42	5		
VSA-4A-7.5-4		50	7.5		
VSA-4C-10-4		70	10		
VSA-4C-15-4		86	15		
VSA-4A-2-4	300	9	2	4	
VSA-4A-3-4		20	3		
VSA-4A-5-4		35	5		
VSA-4C-7.5-4		49	7.5		
VSA-4C-10-4		68	10		
VSA-4C-15-4		83	15		
VSA-4A-3-4	350	16	3	4	
VSA-4A-5-4		30	5		
VSA-4C-7.5-4		48	7.5		
VSA-4C-10-4		65	10		
VSA-4C-15-4		80	15		
VSA-4C-3-4	400	15	3	4	
VSA-4C-5-4		29	5		
VSA-4C-7.5-4		45	7.5		
VSA-4C-10-4		61	10		
VSA-4C-15-4		75	15		
VSA-4C-20-4		82	20		
VSA-4C-5-4	500	23	5	4	
VSA-4C-7.5-4		38	7.5		
VSA-4C-10-4		55	10		
VSA-4C-15-4		70	15		
VSA-4C-20-4		77	20		
VSA-4E-25-4		88	25		
VSA-4E-30-4		102	30		
VSA-4E-40-4		120	40		
VSA-5C-5-4	600	17	5	5	
VSA-5C-7.5-4		30	7.5		
VSA-5C-10-4		50	10		
VSA-5C-15-4		64	15		
VSA-5C-20-4		72	20		
VSA-5E-25-4		82	25		
VSA-5E-30-4		100	30		
VSA-5E-40-4		115	40		
VSA-5E-15-4	800	43	15	6	
VSA-5E-20-4		60	20		
VSA-5E-25-4		68	25		
VSA-5E-30-4		88	30		
VSA-5E-40-4		110	40		
VSA-6H-15-4	1000	40	15	6	
VSA-6H-20-4		50	20		
VSA-6H-25-4		62	25		
VSA-6H-30-4		78	30		
VSA-6H-40-4		100	40		
VSA-6H-20-4	1200	42	20	6	
VSA-6H-25-4		55	25		
VSA-6H-30-4		72	30		
VSA-6H-40-4		90	40		
VSA-6H-20-4		1400	30		20
VSA-6H-25-4	42		25		
VSA-6H-30-4	60		30		
VSA-6H-40-4	80		40		
VSA-6H-30-4	1600		48	30	6
VSA-6H-40-4		72	40		

Selection Table 1150 RPM					
Unit No.	GPM	Disch. Head (ft.)	Motor HP	Disch. Size (ins.)	
VSA-4F-.75-6	50	16	0.75	4	
VSA-4A-1-6		28	1		
VSA-4A-1.5-6		31	1.5		
VSA-4C-3-6		36	3		
VSA-4E-5-6		48	5		
VSA-4E-7.5-6		61	7.5		
VSA-4F-.75-6	75	15	0.75	4	
VSA-4A-1-6		23	1		
VSA-4A-1.5-6		29	1.5		
VSA-4C-3-6		35	3		
VSA-4E-5-6		46	5		
VSA-4E-7.5-6		59	7.5		
VSA-4F-.75-6	100	13	0.75	4	
VSA-4A-1-6		20	1		
VSA-4A-1.5-6		27	1.5		
VSA-4C-3-6		33	3		
VSA-4E-5-6		44	5		
VSA-4E-7.5-6		58	7.5		
VSA-4F-.75-6	125	10	0.75	4	
VSA-4A-1-6		18	1		
VSA-4A-1.5-6		25	1.5		
VSA-4C-3-6		31	3		
VSA-4E-5-6		42	5		
VSA-4E-7.5-6		57	7.5		
VSA-4F-.75-6	150	8	0.75	4	
VSA-4A-1-6		13	1		
VSA-4A-1.5-6		21	1.5		
VSA-4A-2-6		24	2		
VSA-4C-3-6		30	3		
VSA-4E-5-6	40	5			
VSA-4E-7.5-6		56	7.5		
VSA-4A-1.5-6	200	16	1.5	4	
VSA-4A-2-6		22	2		
VSA-4C-3-6		28	3		
VSA-4C-5-6		38	5		
VSA-4E-7.5-6		54	7.5		
VSA-4A-1.5-6	250	14	1.5	4	
VSA-4C-2-6		19	2		
VSA-4C-3-6		26	3		
VSA-4C-5-6		35	5		
VSA-4E-7.5-6		50	7.5		
VSA-4E-10-6		58	10		
VSA-4C-2-6	300	15	2	4	
VSA-4C-3-6		23	3		
VSA-4C-5-6		31	5		
VSA-4E-7.5-6		47	7.5		
VSA-4E-10-6		54	10		
VSA-4E-15-6		59	15		
VSA-4C-2-6	350	13	2	4	
VSA-4C-3-6		21	3		
VSA-4C-5-6		28	5		
VSA-4E-7.5-6		42	7.5		
VSA-4E-10-6		50	10		
VSA-4E-15-6		58	15		
VSA-4C-2-6	400	12	2	4	
VSA-4C-3-6		20	3		
VSA-4C-5-6		24	5		
VSA-4E-7.5-6		38	7.5		
VSA-4E-10-6		44	10		
VSA-4E-15-6		57	15		
VSA-4C-3-6	500	15	3	4	
VSA-4C-5-6		23	5		
VSA-4E-7.5-6		31	7.5		
VSA-4E-10-6		42	10		
VSA-4E-15-6		54	15		
VSA-5E-5-6	600	16	5	5	
VSA-5E-7.5-6		29	7.5		
VSA-5E-10-6		40	10		
VSA-5E-15-6		50	15		
VSA-6H-5-6			13		5
VSA-6H-7.5-6	800	25	7.5	6	
VSA-6H-10-6		36	10		
VSA-6H-15-6		47	15		
VSA-6H-7.5-6		17	7.5		
VSA-6H-10-6		29	10		
VSA-6H-15-6	42	15			
VSA-6H-10-6	1200	23	10	6	
VSA-6H-15-6		35	15		
VSA-6H-15-6	1400	28	15		

EXPLANATION OF UNIT NUMBERS

Example VSA-4A-3-4; VSA is the type of pump (suspended wet-pit non-clog sewage pump); -4 is the discharge size (4"); A is the volute size (F = small volute; A or C = medium volutes; E or H = large volutes); -3 is the motor horsepower; and -4 is the motor speed (-4 = 4-pole 1750 rpm; -6 = 6-pole 1150 rpm).

DIMENSIONS: Dimensions are subject to change and should not be used for construction purposes unless certified. All dimensions are in inches unless otherwise noted.

SIMPLEX AND DUPLEX UNITS: While the dimension drawing on this page shows a duplex unit in a basin, the data on the drawing applies to simplex and duplex units.

INLETS: Basins can be furnished with any number of inlets, of the styles shown on this page, in sizes 2 inches thru 8 inches. The inlet depth is determined by job conditions such as distance from farthest fixture and pipe pitch. Indicate size, style and depth of inlet when releasing the basin for fabrication.

Unless otherwise requested, the inlet centerline is directly below the centerline of the manhole.

COVERS: All basin covers are steel. Covers for cast iron and fiberglass basins are bolted onto the top flange of the basin. Covers for steel basins are welded onto the basin shell and, therefore, there is no top flange. Basin covers have required openings for pumps and controls plus a vent connection and a manhole (with cast iron manhole cover).

The standard vent for a sewage pit or basin cover is a 3 inch screwed connection. If local code requires a 4 inch vent connection, it must be so specified when the unit is ordered.

Covers are furnished with bolts and gasketing for gastite field assembly on the basin. Pumps are furnished with bolts and gasketing for gastite field assembly on the cover.

SECTIONAL BASINS: Standard steel and fiberglass basins are built in one section. Multisection basins are furnished only when specified.

Standard cast iron basins are built in one, two, three or more sections, depending on the basin depth. The intermediate flanges of multisection basins have the same outside diameter and bolt hole dimensions as the top flange on which the cover is mounted. Bolts and gasketing are furnished for field assembly of the sections.

SQUARE BASINS: Square and rectangular basins are available in steel construction only. Cast iron and fiberglass basins are not available in these shapes.

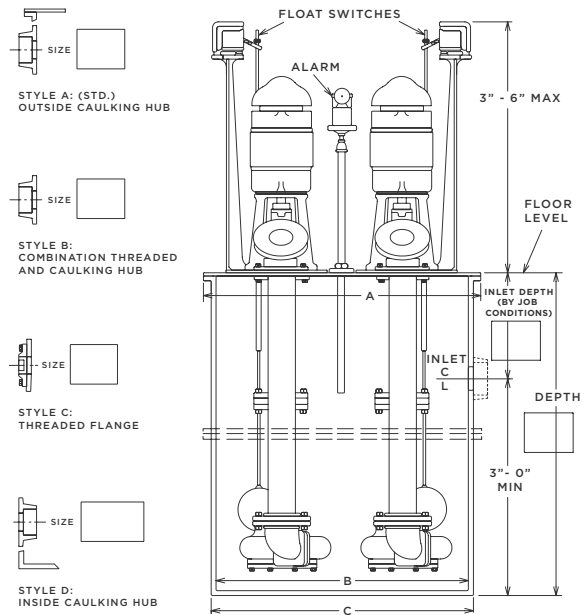

Dimensions Table						
Basin Dimensions				Top Flange And Mating Flanges of Cast Iron Basins & Fiberglass Basins		
B Basin Inside Dia.	Approx. Gals. Per Ft. Of Depth	A Cover Dia.	C Approx.	No. Of Tappings	Bolt Size	Bolt Circle Dia.
30	37	34	31	6	0.375	32.5
36	55	40	37	6	0.375	38.5
42	70	46	43	8	0.5	44.5
48	95	53	49	8	0.5	51
54	120	60	55	12	0.5	57
60	150	66	61	12	0.5	63
72	210	78	73	16	0.5	75
84	290	90	85	16	0.5	87

Recommended Minimum Pit & Basin Sizes				
Pump Model	Round		Square	
	Simplex	Duplex	Simplex	Duplex
VSA-4F, 3F	30" DIA.	36" DIA.	30" X 30"	36" X 36"
VSA-4A, 3A	30" DIA.	42" DIA.	30" X 30"	42" X 42"
VSA-4C, 5C	36" DIA.	48" DIA.	36" X 36"	48" X 48"
VSA-4E, 5E	42" DIA.	48" DIA.	42" X 42"	48" X 48"
VSA-6H	48" DIA.	54" DIA.	48" X 48"	54" X 54"



ADDRESS: 1144 Utica Avenue, Brooklyn, NY 11203 **TEL:** (718) 451-2000 **URL:** federalpumps.com