

CECO Fybroc

FYBROC®
SERIES 8500

FIBERGLASS CONSTRUCTION
FOR CORROSIVE APPLICATIONS

**Patent
Pending**



Fybroc® Vertical Turbine Pumps

BULLETIN 85B1

FYBROC – THE LEADER IN CORROSION-RESISTANT FIBERGLASS PUMPING EQUIPMENT

Fybroc, the world's first and largest manufacturer of fiberglass reinforced centrifugal pumps, has led the way in the design and engineering of the industry's most technically advanced pumps for handling corrosives and other difficult liquids.

Fybroc continues this leadership role with the introduction of *the first and only FRP (Fiberglass Reinforced Polymer) Vertical Turbine Pump (VTP)*. Utilizing state of the art Resin Transfer Molding (RTM) techniques and proprietary wax core technology, Fybroc has created the only VTP with completely homogenous hydraulic components (impellers, bowls and suction bell). Each part is molded as one completely integral FRP component with no seams, joints or secondary adhesives.

These revolutionary manufacturing techniques have allowed Fybroc to create the industry's first homogenous mixed flow hydraulic passages, thus giving Fybroc the ability to introduce the first multi-stage FRP VTP. All of the pump components in contact with the fluid medium are corrosion resistant FRP with the exception of the shaft and component hardware.



MATERIALS OF CONSTRUCTION ARE AVAILABLE FOR A WIDE RANGE OF CORROSIVE LIQUIDS

Only Fybroc has the flexibility in materials selection to solve your difficult corrosive or abrasive pump problems.

- **VR-1**, vinyl ester resin: used for the vast majority of corrosive applications including most acids, caustics, brines, sea water, and wastewater.
- **VR-1 BPO-DMA**, vinyl ester resin with BPO-DMA cure system: used to accommodate applications for specific corrosion resistance to bleaches such as sodium hypochlorite (NaOCl) and hydrogen peroxide (H₂O₂).
- **EY-2**, epoxy resin: offers outstanding chemical resistance for aggressive chemical/compounds, acids, and solvents. Ideal for high concentrations of sulfuric acid (up to 98%).
- **METALLIC COMPONENTS**: the pump shaft and wetted hardware are furnished in materials selected for the specific application. Standard materials offered are 316SS, Alloy 20, Titanium, or Hastelloy-C. Additional materials are available upon request. For further information on corrosion resistance to specific chemicals, please refer to the Fybroc website at www.cecoenviro.com.

DESIGN FEATURES OF THE FYBROC SERIES 8500 VERTICAL TURBINE PUMP

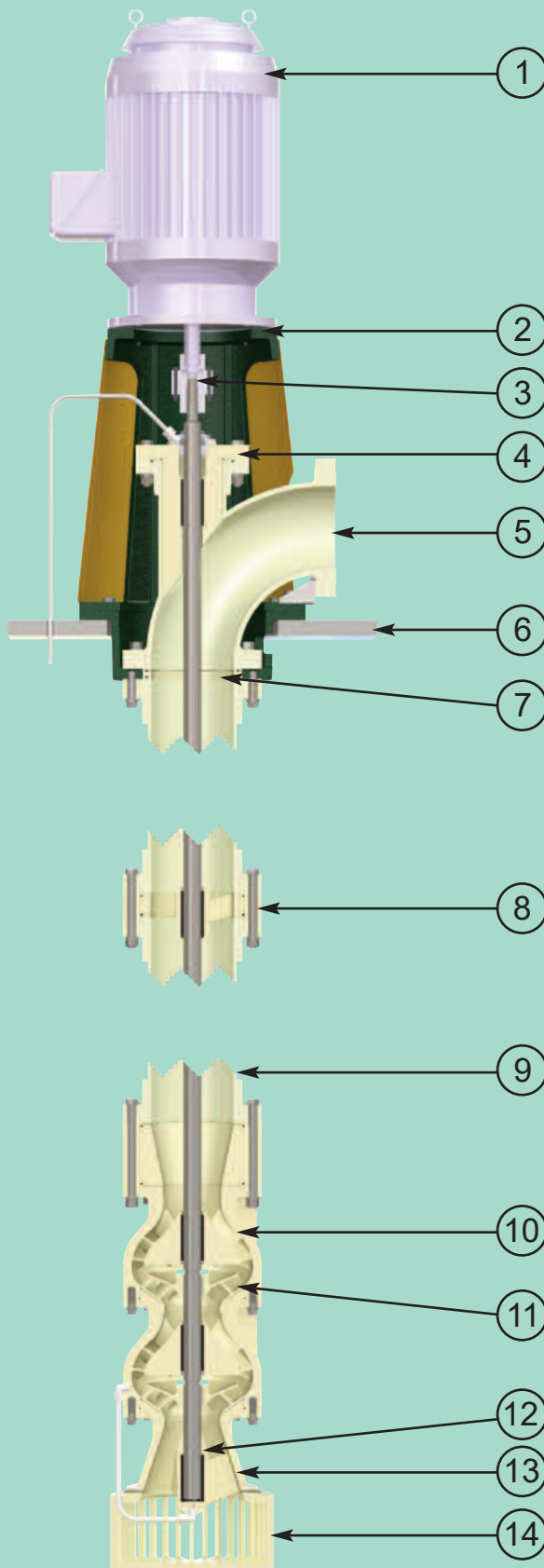

1. **MOTOR** – NEMA/IEC, T E F C , vertical solid shaft, high-thrust, P-base.
2. **PEDESTAL** is powder coated ductile iron.
3. **COUPLING** – rigid, adjustable.
4. **FRP STUFFING BOX** is angled to match the internal contour of the discharge elbow. It houses a replaceable PPS** sleeve bearing and can accommodate several shaft sealing options.
5. **FRP DISCHARGE ELBOW** is custom made with a long radius design to minimize hydraulic losses. Discharge flange is 150# flat face (DIN PN 10/16 Available).
6. **FRP MOUNTING PLATE**
7. **FRP SEAL PLATE** is used to contain the process fluid between the discharge elbow and column pipe.
8. **FRP BEARING HOLDER** machined to pilot between column flanges. Houses a fluted PPS sleeve bearing, designed to flush particles quickly using the process fluid.
9. **FRP COLUMN ASSEMBLIES** are available in multiple configurations depending on pump length.
10. **FRP BOWL** molded using innovative RTM and wax core technology. Each bowl houses a fluted, product flushed PPS sleeve bearing.
11. **FRP CLOSED IMPELLER** molded as one homogeneous piece, using innovative RTM and wax core technology.
12. **FRP BEARING CAP** to prevent particle build-up in the suction bell bearing.
13. **FRP SUCTION BELL**, with integral web/bearing holder. The bearing is flushed using a bypass line from the bowl.
14. **FRP BASKET STRAINER** is optional and designed to prevent large particles from entering the pump.

** PPS (Teflon® and carbon filled polyphenylene sulfide)

FYBROC SERIES 8500 – PARTS AND STANDARD MATERIALS OF CONSTRUCTION

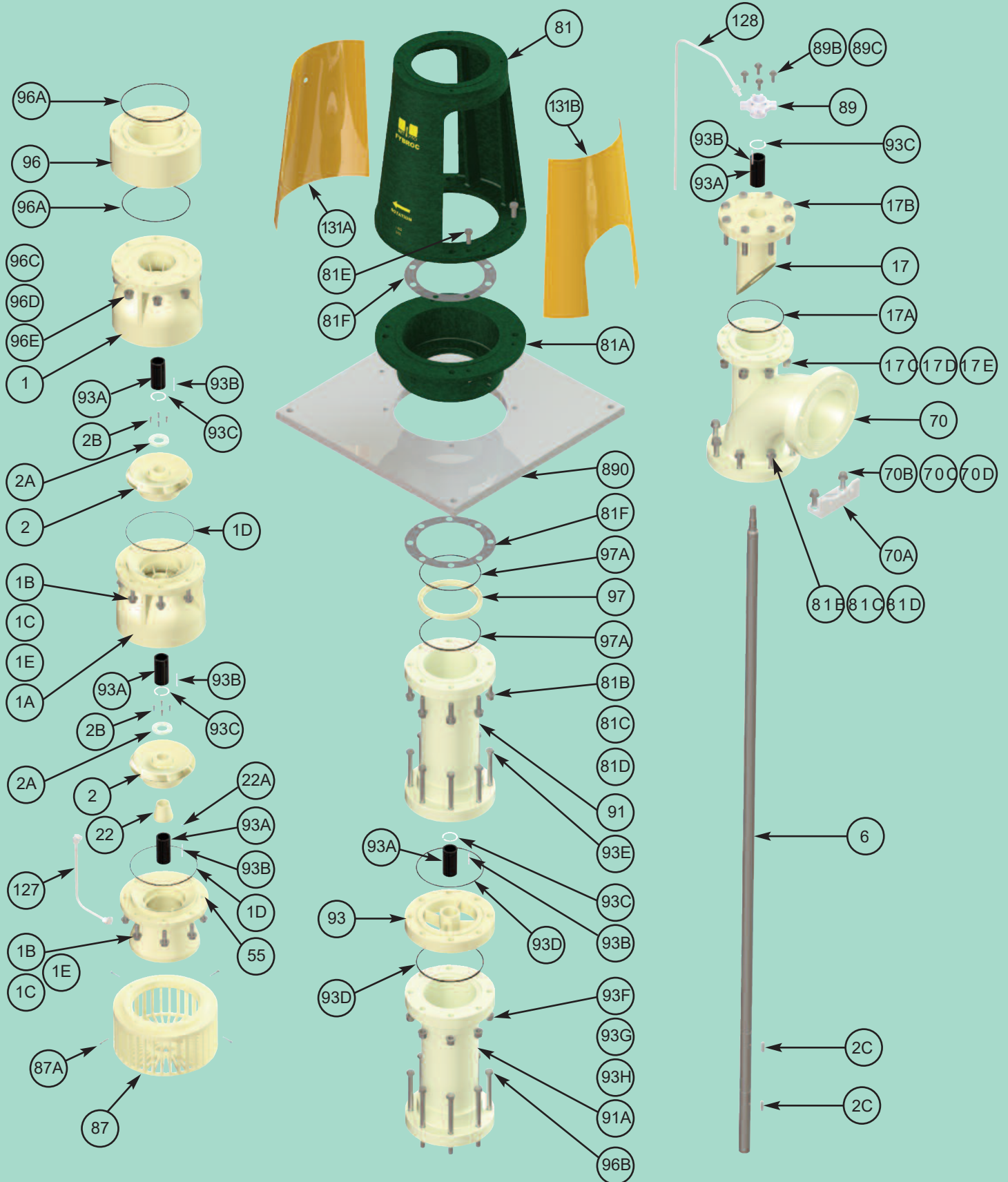

Item Number	Description	Standard Material
1	Bowl (Discharge)	VR-1
1A	Bowl (Intermediate)	VR-1
1B	Bolt, Bowl	316 SS
1C	Flat Washer, Bowl	316 SS
1D	O-Ring, Bowl	Viton
1E	Lock Washer, Bowl	316 SS
2	Impeller	VR-1
2A	Impeller Locking Ring	VR-1
2B	Impeller Screw	316 SS
2C	Key, Impeller	316 SS
6	Shaft	316 SS
17	Stuffing Box	VR-1
17A	O-Ring, Stuffing Box	316 SS
17B	Bolt, Stuffing Box	316 SS
17C	Flat Washer, Stuffing Box	316 SS
17D	Lock Washer, Stuffing Box	316 SS
17E	Hex Nut, Stuffing Box	316 SS
22	Lower Bearing Cap	VR-1
22A	Bearing Cap Set Screw	316 SS
55	Suction Bell	VR-1
70	Discharge Elbow	VR-1
70A	Elbow Support	Steel
70B	Bolt, Elbow Support	316 SS
70C	Flat Washer	316 SS
70D	Lock Washer, Elbow Support	316 SS
81	Upper Pedestal	Ductile Iron
81A	Lower Pedestal	Ductile Iron
81B	Hex Bolt, Lower Pedestal	316 SS
81C	Flat Washer, Lower Pedestal	316 SS
81D	Lock Washer, Lower Pedestal	316 SS
81E	Hex Bolt, Upper Pedestal	316 SS

Item Number	Description	Standard Material
81F	Gasket, Lower Pedestal	Viton
87	Strainer Basket	VR-1
87A	Screw, Strainer	316 SS
89	Single Cartridge Seal	Assembly
89B	Bolt, Mechanical Seal	316 SS
89C	Flat Washer, Mechanical Seal	316 SS
91	Column (Upper)	VR-1
91A	Column (Intermediate)	VR-1
93	Column Bearing Holder	VR-1
93A	Sleeve Bearing	PPS
93B	Sleeve Bearing Pin	Teflon
93C	Sleeve Bearing Snap Ring	Polypro
93D	O-Ring, Bearing Holder	Viton
93E	Bolt, Bearing Holder	316 SS
93F	Flat Washer, Bearing Holder	316 SS
93G	Lock Washer, Bearing Holder	316 SS
93H	Hex Nut, Bearing Holder	316 SS
96	Spool Piece	VR-1
96A	O-Ring, Spool Piece	Viton
96B	Bolt, Spool Piece	316 SS
96C	Flat Washer, Spool Piece	316 SS
96D	Lock Washer, Spool Piece	316 SS
96E	Hex Nut, Spool Piece	316 SS
97	Sealing Plate	VR-1
97A	O-Ring, Sealing Plate	Viton
127	Flush Tubing, Suction Bell	Polypro
128	Flush Tubing, Mechanical Seal	Polypro
131A	Coupling Guard – Back	Steel
131B	Coupling Guard – Front	Steel
890	Mounting Plate	FRP

Note: Above represents typical configuration, other materials are available.

FYBROC SERIES 8500 – HYDRAULIC COVERAGE CHARTS

1450 RPM

50 HERTZ

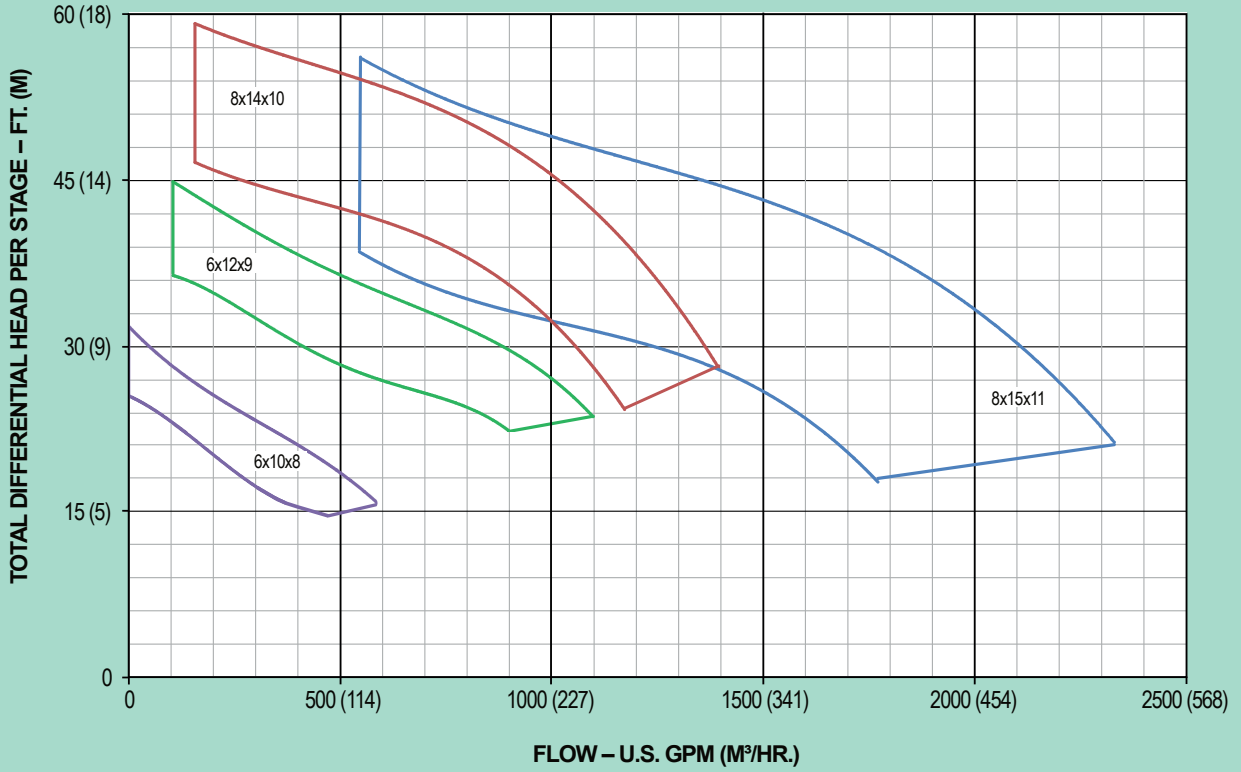

1750 RPM

60 HERTZ

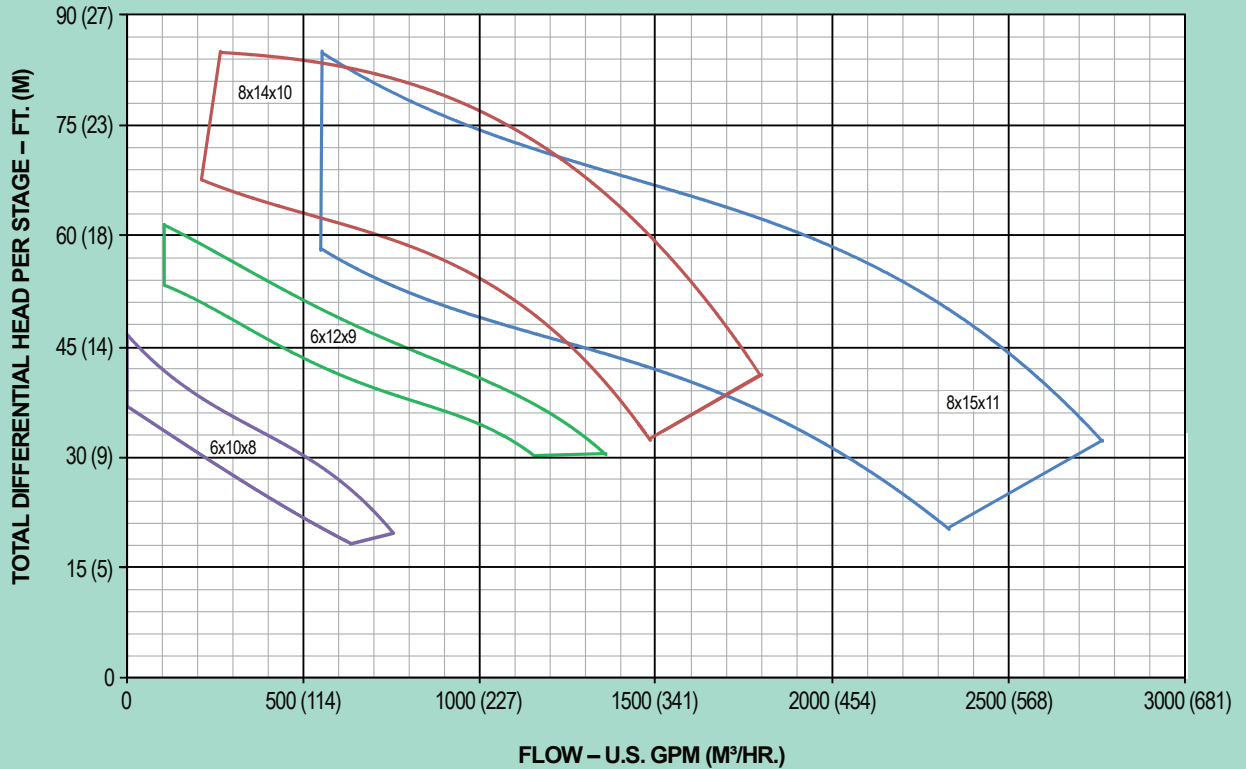

FYBROC SERIES 8500 – PUMP DIMENSIONS

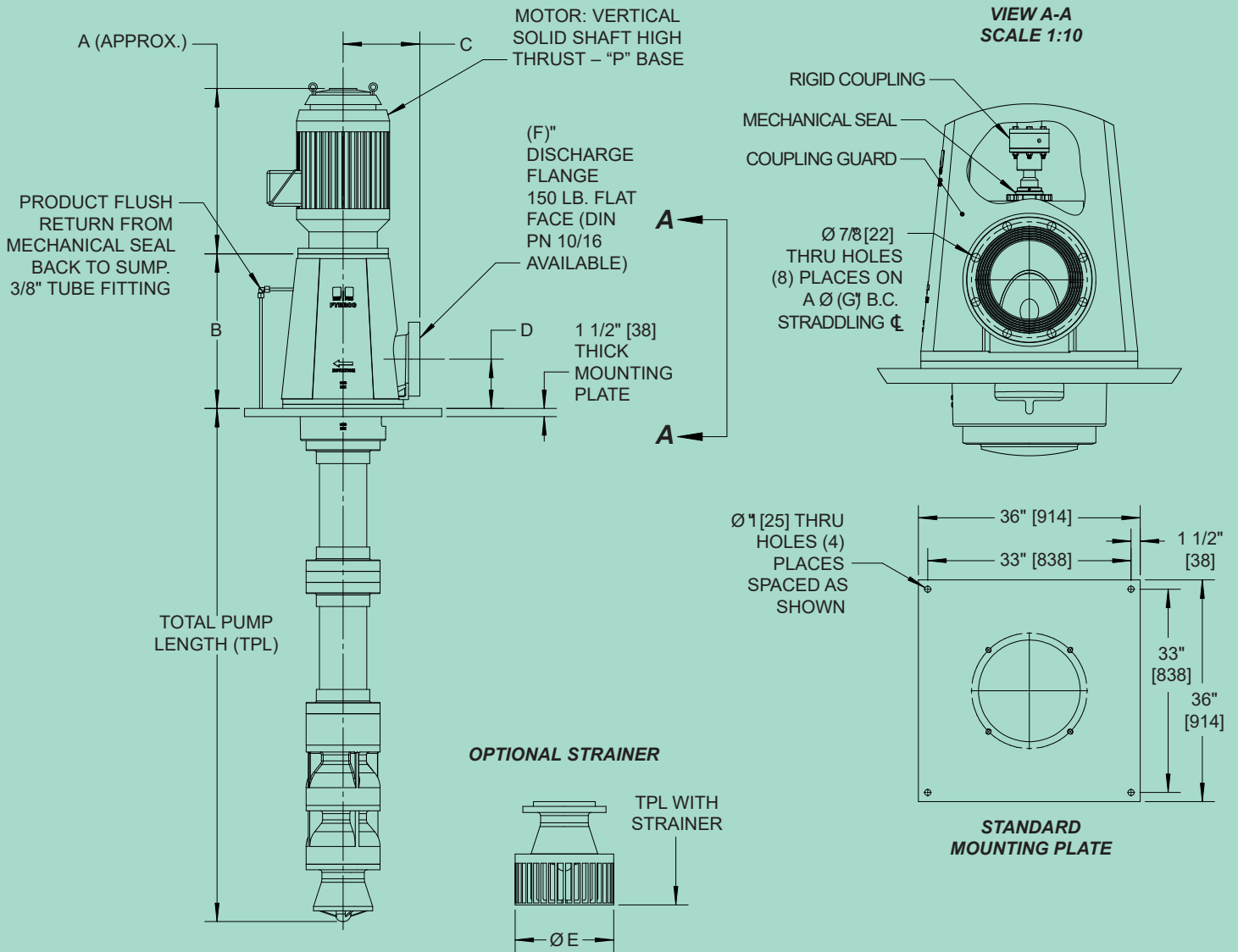

MOTOR FRAME DIMENSIONS

MOTOR FRAME	A (INCHES) [mm]*
182-184 VP	19 [483]
213-215 VP	19 [483]
254-256 VP	25 [635]
284-286 VP	28 [711]
324-326 VP	30 [762]
364-365 VP	32 [813]
405 VP	47 [1194]
444 VP	48 [1219]
447 VP	52 [1321]

DIMENSIONS

	6X10X8	6X12X9	8X14X10	8X15X11
B	22 1/8 [562]	22 1/8 [562]	28 1/4 [718]	28 1/4 [718]
C	11 1/2 [292]	11 1/2 [292]	14 [356]	14 [356]
D	8 [203]	8 [203]	9 [229]	9 [229]
E	13 1/2 [343]	13 1/2 [343]	13 1/2 [343]	16 [406]
F	6 [152]	6 [152]	8 [203]	8 [203]
G	9 1/2 [241]	9 1/2 [241]	11 3/4 [299]	11 3/4 [299]

*:“A” DIMENSION IS APPROXIMATE AND MAY VARY ACCORDING TO MOTOR MANUFACTURER.
NOTE: ALL DIMENSIONS IN INCHES AND [MILLIMETERS].

Series 8500 Specifications

Series	8500 - VERTICAL TURBINE PUMP			
Size	6 x 10 x 8	6x12x9	8x14x10	8x15x11
BEP Flow (1750 RPM)	600 GPM (136 M ³ /HR)	1200 GPM (272 M ³ /HR)	1200 GPM (272 M ³ /HR)	2000 GPM (454 M ³ /HR)
BEP Head/Stage (1750 RPM)	26 FT (8 M)	40 FT (12 M)	70 FT (21 M)	60 FT (18 M)
Max Power/Stage (1750 RPM)	7.5 HP (5.5 KW)	15 HP (11 KW)	30 HP (22 KW)	40 HP (30 KW)
Material	FRP with Stainless Steel Shaft & Hardware - Standard (Other Alloys - Optional)			

ABOUT CECO ENVIRONMENTAL PUMP SOLUTIONS

Our Fluid Handling Solutions segment combines the resources of our four internationally recognized comprehensive lines of high-quality filters and pumps: Dean Pump, Fybroc, Mefiag and Sethco. Our Dean, Fybroc, and Sethco pumps are designed to handle the niches of corrosive, abrasive, or high temperature liquids. These pumps provide excellent performance for tough applications including pumping of acids, brines, caustics, bleaches, seawater, high temperature liquids and a wide variety of waste liquids for a broad range of applications including the chemical, petrochemical, metal finishing, wastewater treatment, desalination and aquarium/aquaculture markets. For more information, visit www.cecoviro.com.

ABOUT CECO ENVIRONMENTAL

CECO Environmental is a leading global environmental technology company focused on critical solutions in the product recovery, air pollution control, fluid handling and liquid filtration segments. Through its well-known brands, CECO provides a wide spectrum of products and services including dampers and diverters, cyclonic technology, thermal oxidizers, filtration systems, scrubbers, fluid handling equipment, plant engineered services and engineered design build fabrication. For more information visit www.cecoviro.com.



700 Emlen Way • Telford, PA 18969
 P: 215.723.8155 • TOLL-FREE: 800.392.7621 • F: 215.723.2197
infoFHS@OneCECO.com • www.cecoviro.com/fybroc

