

VIKING® LID-EASE

BASKET-TYPE LINE STRAINERS

Section	640
Page	640.1
Issue	G

FEATURES

- LIGHT IN WEIGHT
- EASY TO CLEAN
- LOW PRESSURE DROP
- SMALL IN OVERALL DIMENSION
- VIKING QUALITY CONSTRUCTION IN CAST IRON OR STAINLESS STEEL

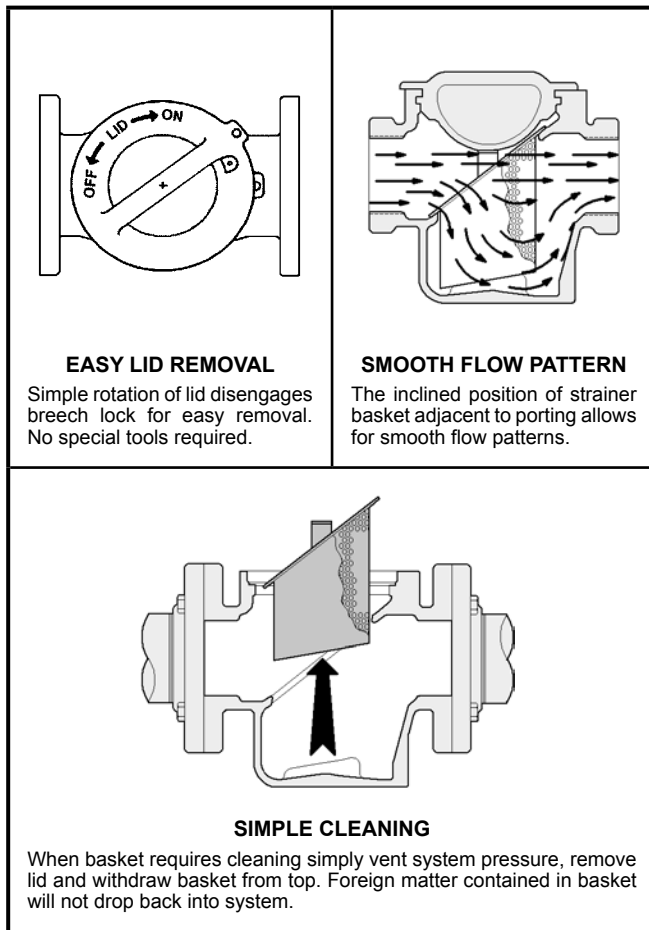

Viking Lid-Ease® Simplex Strainers provide protection for your pumping system with low pressure drop. The inclined position of the strainer basket adjacent to the porting provides smooth flow patterns not found in conventional basket-type strainers.

Viking's Lid-Ease Simplex Strainers reduce cleaning problems encountered with conventional strainers. Simple lid rotation disengages the breech lock type lid permitting easy removal of the basket. Basket is removed from the top of the strainer, possibly eliminating the need to completely drain the system or allowing foreign matter to drop back into the line when the strainer is cleaned. The relatively small port-to-port dimensions of the strainer allow easy installation.



Viking Lid-Ease Simplex Strainers are designed with a weatherseal lid to protect the breech lock area from exterior elements and prevent air infiltration into the pump suction. Strainers are also equipped with a drain plug for complete draining of strainer if needed.

Tapped or flanged end ports available. See page 2.

Section	640
Page	640.2
Issue	G

VIKING® LID-EASE BASKET-TYPE LINE STRAINERS

MODEL NUMBERING CODE

F - 1 020 - I IRN - 01 3

PRODUCT:
F = Strainer

PRODUCT TYPE:
1 = Simplex Type

PORT SIZES:
007 = 3/4"
010 = 1"
015 = 1 1/2"
020 = 2"
030 = 3"
040 = 4"
060 = 6"
080 = 8"

MATERIAL:
IRN = Iron
SST = Stainless Steel

BASKET MESH:
0 = No Mesh
1 = 10 Mesh
2 = 20 Mesh
3 = 40 Mesh
4 = 60 Mesh
5 = 80 Mesh
6 = 100 Mesh

PORT TYPES:
I = Internal Tapped Threads
F = Flanged

ELASTOMER SEAL:
01 = Buna-N – Cast Iron
02 = Viton® – Stainless Steel

Example: F-1020-IIRN-013. A cast iron simplex strainer with 2" NPT ports, Buna-N O-Ring seal, 40 mesh basket.

Viton® — Registered trademark of DuPont Performance Elastomers.

Kits available in Buna, Viton and PTFE when alternate material needed

OPTIONS



OPTIONAL MAGNETIC INSERTS

Magnetic inserts are available for trapping ferrous particles too small for the basket straining media. The inserts are secured to basket handle using a spring clip which makes removal for cleaning a simple task.



OPTIONAL PRESSURE DIFFERENTIAL INDICATORS

Pressure differential indicators are available as an option to indicate when basket needs to be cleaned. Consult Factory.

VIKING® LID-EASE

BASKET-TYPE LINE STRAINERS

Section	640
Page	640.3
Issue	G

FEATURES – SPECIFICATIONS



Tapped Ports
3/4", 1", 1½", 2" & 3"



Flanged Ports
2", 3", 4", 6" & 8"

Strainer bodies are available in cast iron or stainless steel materials. For normal use, baskets of double wall construction are recommended. The inner stainless steel screen (10, 20, 40, 60, 80 or 100 mesh) is rigidly supported by a perforated stainless steel basket having maximum hoop strength so that a high differential pressure over the

basket will not burst or distort the basket to the extent that it cannot be withdrawn from the body.

Stainless steel construction can also be used for steel requirements in the chemical, petrochemical and pharmaceutical industries.

SPECIFICATIONS — AVAILABLE MESH SIZES

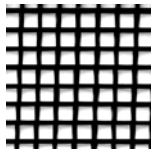
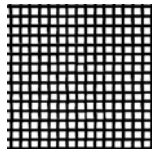
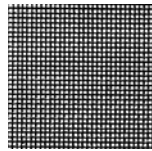
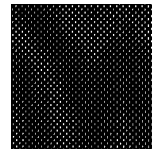
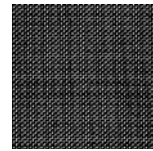
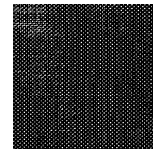
						
Mesh	10	20	40	60	80	100
Opening (Inches)	.075	.034	.015	.0092	.007	.0055
Opening (Microns)	1910	860	380	230	190	140

SPECIFICATIONS — STRAINERS

Model Number	Port Size	Nominal Pipe Area	① Standard Basket Perforation	Basket Surface Area	Basket Free Area	Ratio Free Area / Port Area	Maximum Basket Differential Pressure
	Inches	Inches ²	Inches	Inches ²	Inches ²		PSID
F-1007	¾"	.53	.156	8.6	5.4	10.2	150
F-1010	1"	.86	.156	8.6	5.4	6.3	150
F-1015	1½"	2.04	.156	17.9	11.3	5.5	150
F-1020	2"	3.36	.188	33	16.8	5.0	150
F-1030	3"	7.39	.188	66	33.7	4.6	125
F-1040	4"	12.73	.188	113	57.6	4.5	125
F-1060	6"	28.9	.188	233	118.8	4.1	75
F-1080	8"	50.0	.188	636	324.7	6.5	50

① For other basket perforations, consult the factory.

Section	640
Page	640.4
Issue	G

VIKING® LID-EASE

BASKET-TYPE LINE STRAINERS

SPECIFICATIONS

CONSTRUCTION — CAST IRON

Body & Lid	O-Ring for Lid	Basket Material
Cast Iron	① Buna-N	316 Stainless Steel

① Buna-N O-Ring standard, Viton® and PTFE (Derivative) Encapsulated optional.
For other materials consult factory.

SPECIFICATIONS — CAST IRON

Model Numbers	Port Size	① Nominal Capacity Suction Rating	Rated System Pressure	② Temperature Range		Approximate Shipping Weight
	Inches			GPM	PSI	
F-1007-IIRN	③ ¾"	20	200	-40 to 400		7
F-1010-IIRN	③ 1"	30	200	-40 to 400		7
F-1015-IIRN	③ 1½"	50	200	-40 to 400		9
F-1020-FIRN	④ 2"	100	200	-40 to 400		16
F-1020-IIRN	③ 2"					13
F-1030-FIRN	④ 3"	200	⑤ 125	-40 to 400		40
F-1030-IIRN	③ 3"					30
F-1040-FIRN	④ 4"	400	⑤ 125	-40 to 400		73
F-1060-FIRN	④ 6"	800	⑤ 125	-40 to 400		120
F-1080-FIRN	④ 8"	1500	⑤ 125	-40 to 400		300



Viking Lid-Ease® Strainer
1½" size, Cast Iron
with tapped ports.

- ① Capacity based on approx. 1 PSI pressure drop with 40 mesh basket and 38 SSU liquid.
- ② Elastomers suitable for temperature must be used.
- ③ Tapped ports compatible with standard pipe. (NPT Threads)
- ④ Flanged ports suitable for use with 125# ANSI cast iron or 150# ANSI steel companion flanges or flanged fittings.
- ⑤ 175 PSI on liquid temperature below 150° F.

CONSTRUCTION — STAINLESS STEEL

Body & Lid	O-Ring for Lid	Basket Material
316 Stainless Steel	Viton®	316 Stainless Steel

SPECIFICATIONS — STAINLESS STEEL

Model Numbers	Port Size	① Nominal Capacity Suction Rating	Rated System Pressure	② Temperature Range		Approximate Shipping Weight
	Inches			GPM	PSI	
F-1007-ISST	③ ¾"	20	200	-100 to 400		7
F-1010-ISST	③ 1"	30	200	-100 to 400		7
F-1015-ISST	③ 1½"	50	200	-100 to 400		10
F-1020-FSST	④ 2"	100	200	-100 to 400		20
F-1020-ISST	③ 2"					14
F-1030-FSST	④ 3"	200	⑤ 125	-100 to 400		44
F-1040-FSST	④ 4"	400	⑤ 125	-100 to 400		77
F-1060-FSST	④ 6"	800	⑤ 125	-100 to 400		128

- ① Capacity based on approx. 1 PSI pressure drop with 40 mesh basket and 38 SSU liquid.
- ② Elastomers suitable for temperature must be used.
- ③ Tapped ports compatible with standard pipe. (NPT Threads)
- ④ Flanged ports suitable for use with 150# ANSI steel or stainless steel companion flanges or flanged fittings.
- ⑤ 175 PSI on liquid temperature below 150° F.



Viking Lid-Ease Strainer
4" Size, Stainless Steel
with flanged ports.

Viton® — Registered trademark of DuPont Performance Elastomers.

VIKING® LID-EASE

BASKET-TYPE LINE STRAINERS

Section	640
Page	640.5
Issue	G

DIMENSIONS

These dimensions are average and not for construction purposes. Certified prints on request.

DIMENSIONS— STRAINERS WITH TAPPED PORTS

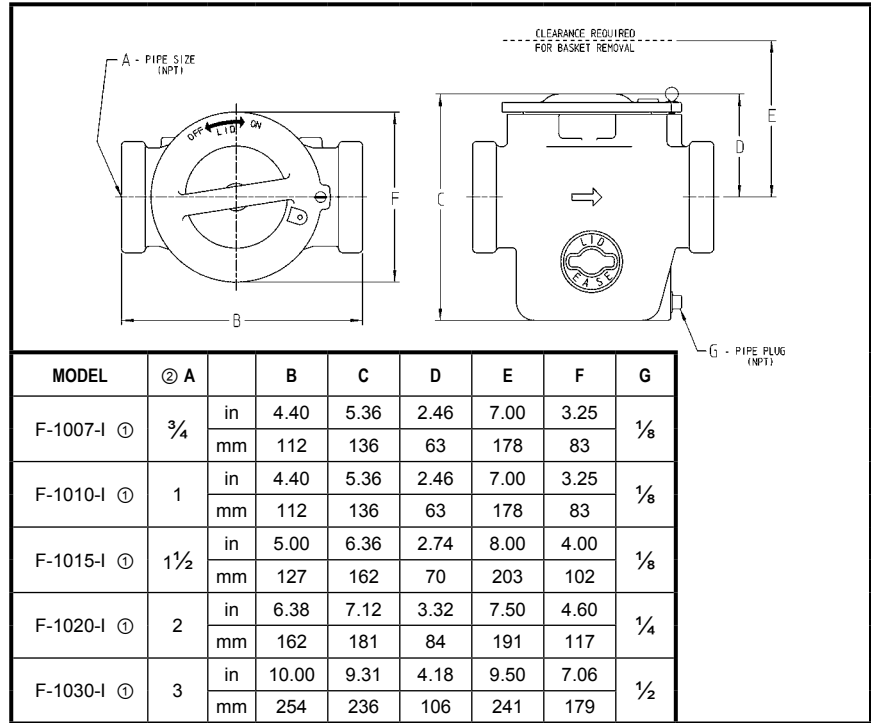

① IRN—Iron, SST—Stainless Steel. (See specifications tables for available materials of construction).

② Tapped ports compatible with standard pipe. (NPT Threads)

These dimensions are average and not for construction purposes. Certified prints on request.

DIMENSIONS— STRAINERS WITH FLANGED PORTS

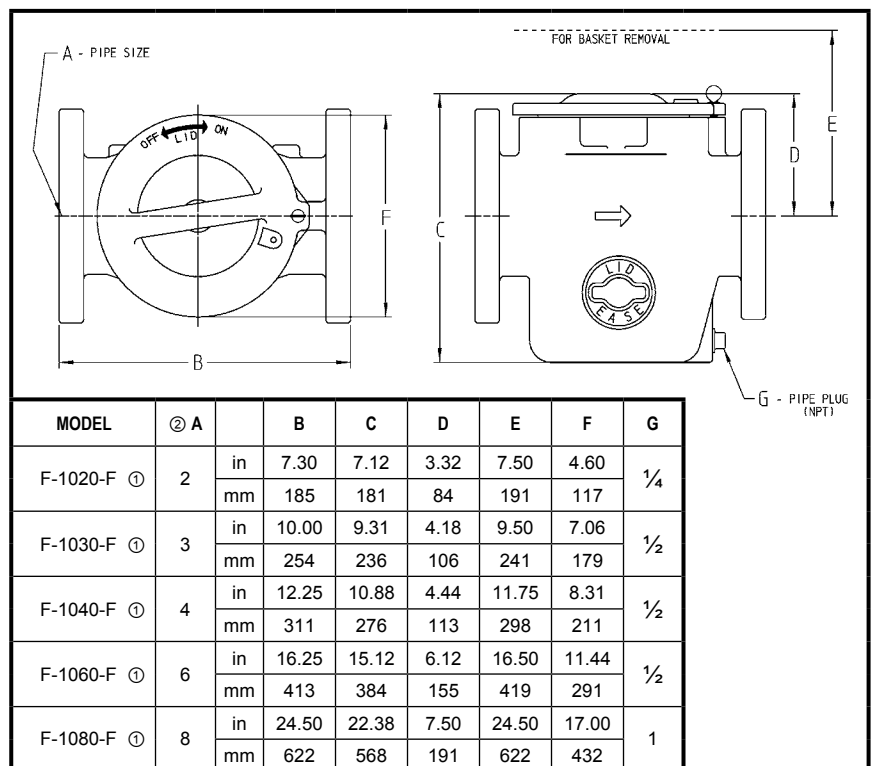

① IRN—Iron, SST—Stainless Steel (See specifications tables for available materials of construction).

② Flanged ports suitable for use with 125# ANSI cast Iron or 150# ANSI steel or stainless steel companion flanges or flanged fittings.

Section	640
Page	640.6
Issue	G

VIKING® LID-EASE

BASKET-TYPE LINE STRAINERS

PRESSURE DROP INFORMATION

Example: To determine the pressure drop across a strainer for a pump with 3" ports producing a flow rate of 150 GPM, with a viscosity of 700 SSU; first, determine the nominal pressure differential for the 3" strainer (F-1030) by following 150 GPM vertically until it intersects the F-1030 curve then read horizontally on the Pressure Drop Curve

the nominal pressure differential (.7 psi). Using the Correction Curves, enter vertically at 700 SSU and proceed until intersecting the 60 mesh curve, then read the correction factor horizontally (3.0). Therefore, the actual pressure drop will be $3.0 \times .7 = 2.1$ psi (4.28" of Hg.)

PRESSURE DROP CURVES

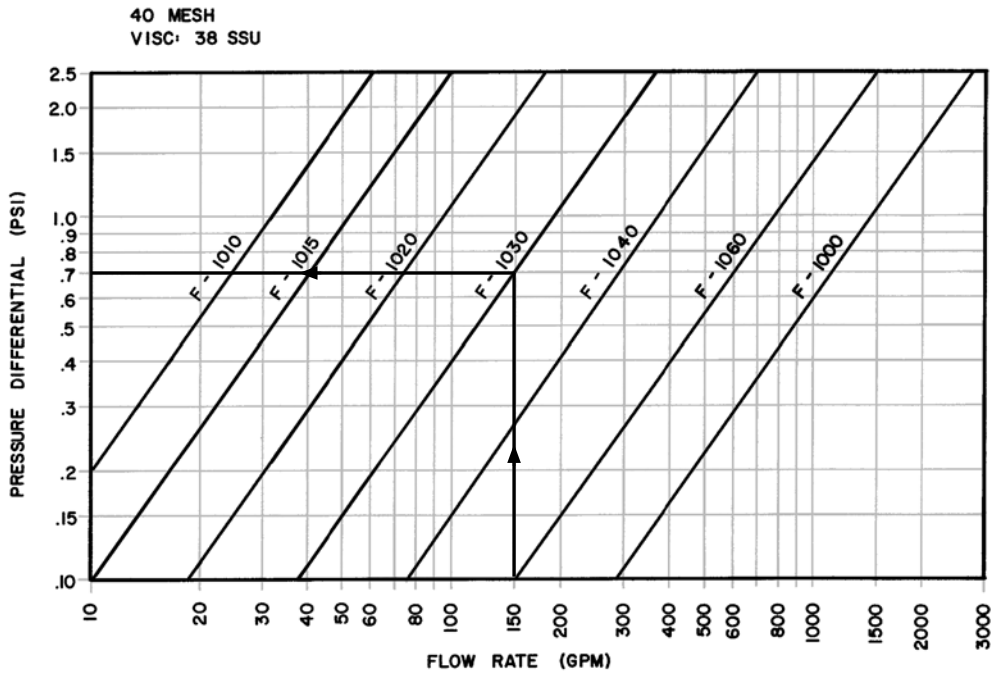

CORRECTION CURVES

